

01.11.2008 V02, good  
 12.11.2008 V03, added XBSLEEP

OpenDCC Throttle  
**Throttle V1.0**  
 15.11.2008 13:26:23  
 Sheet: 1/2

Note: a trick on eagle: set bottom to round pads (ignore library)

(c) W. Kufer, 2008 www.opendcc.de

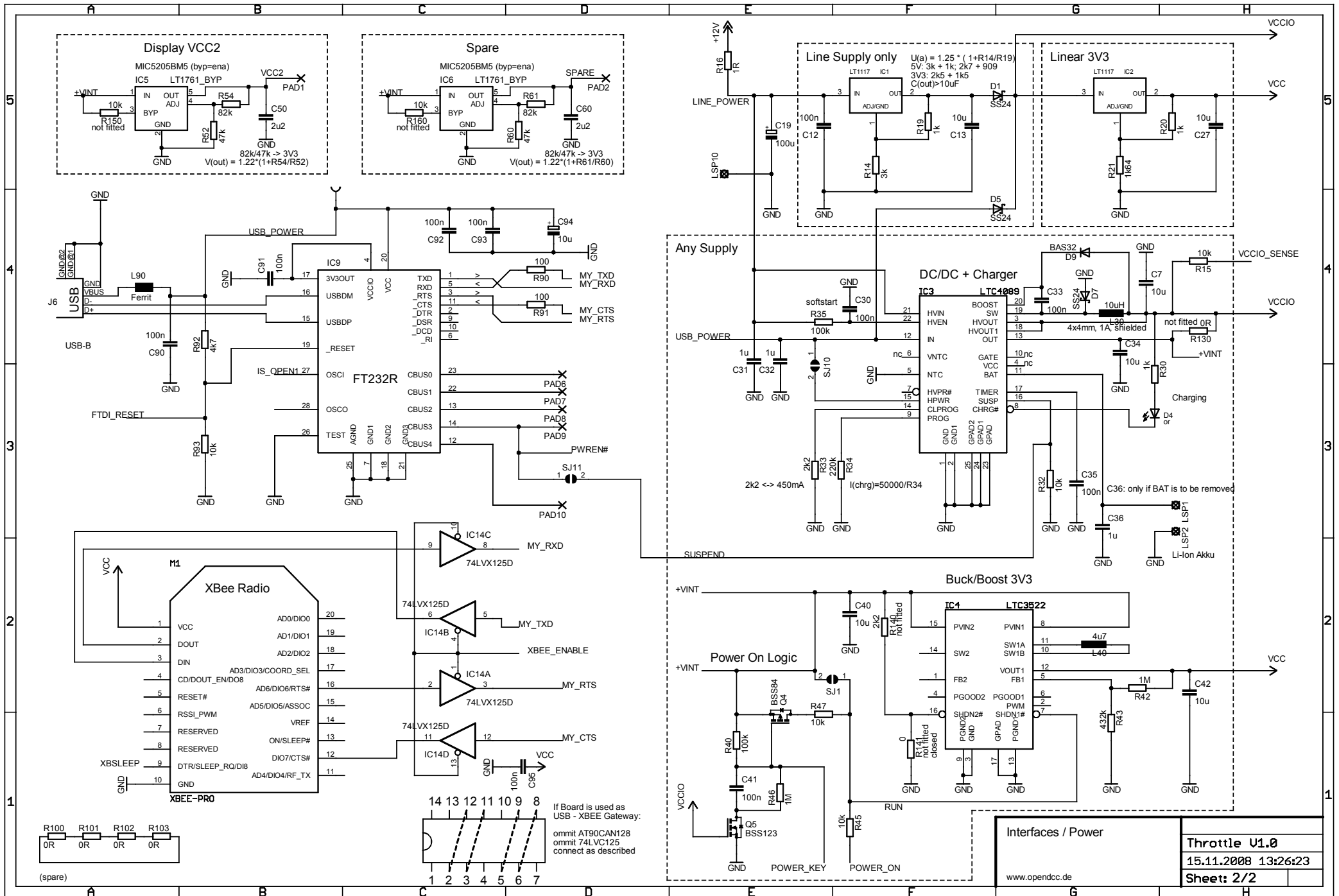

Interfaces / Power	
www.opendcc.de	
<b>Throttle V1.0</b>	
15.11.2008 13:26:23	
Sheet: 2/2	